

# Modeling and Simulation Tools for Teaching Protective Relaying Design and Application for the Smart Grid

J. Ren, M. Kezunovic

Department of Electrical and Computer Engineering, Texas A&M University  
College Station, TX 77843-3128, USA  
Email: j.f.ren@neo.tamu.edu

**Abstract**—As the smart grid concepts are emphasized lately the need to modernize the power engineering education is also well recognized. This paper presents a set of newly developed modeling, simulation and testing tools aimed at better understanding the design concept and related applications for protective relaying and substation automation solutions for the smart grid. Since the smart grid applications require integration of data from multiple IEDs, understanding properties of each IED type in detail, as well as their responses to the power system events is needed. In addition, understanding the communication requirements to perform data integration is also important. To illustrate how the mentioned smart grid issues may be taught, the following advanced teaching approaches are presented: 1) Use of modeling and simulation means to better understand interaction between the relays and power system; 2) Use of IED test facilities to better understand performance of physical devices used for protection, monitoring and control; 3) Utilization of communication network modeling tools to simulate the communication network within Substation Automation System (SAS). Examples showing the use of proposed techniques for teaching the fundamentals and applications are presented. The examples demonstrate the adequacy and efficiency of the proposed techniques.

**Keywords**—Smart grid, power engineering education, modeling, protective relaying, simulation, intelligent electronic device (IED), substation automation system (SAS)

## I. INTRODUCTION

The Smart grid deployment is a significant effort aimed at modernizing the 21<sup>st</sup> century power grid [1]. It encompasses several new concepts in the development of smart grid infrastructure, application of information technologies and implementation of applications [2]. The smart grid solutions often require integration of various types of data from multiple IEDs. The understanding of operating characteristics of each IED type and their behavior under various power system events is needed to develop new smart grid designs and applications. The multifunctional IEDs provide both operational data (samples of voltage, current and contact data) and nonoperational data (logic, event and oscillography files), which can be effectively utilized for adaptive relaying, wide-area protection and substation automation applications. The role of digital multifunctional relaying in monitoring, control, power quality and asset management applications is gaining attention in the education due to its importance in understanding and implementing the smart grid developments.

One convenient and yet powerful way for teaching protective relaying design and application is to use modeling and simulation techniques.

The role of modeling and simulation has been widely recognized throughout the history of power engineering education since the computers capable of performing the complex simulations became available [3]-[5]. A number of efforts have been made in this direction. They range from emphasizing the design of full-blown operator training simulator [6]-[8], to powerful graphical interfaces [9]-[11]. Most of the emphasis was placed on developing either customized packages or adopting some conventional solution. Recent survey of engineering tools used to integrate different technologies into diverse modeling and simulation environments show the lack of solutions that can seamlessly represent interaction between power systems and related controllers and communication channels [12].

Some advanced features, such as synchronized phasor measuring, digital fault recording and network-based communicating have been embedded into modern relays, which are also known as multifunctional relays. Such features can be effectively used for the purpose of substation automation and data integration. The new tools for modeling and simulating the substation communication networks are needed to better understand the design and application concepts, as well as the interoperability issues.

A set of newly developed modeling and simulation tools aimed at better understanding the design concept and related applications for protective relaying, as well as substation communication and automation solutions are presented. These tools include a set of software, named MERIT 2000 developed using MATLAB/SIMULINK [13] [14], simulation techniques based on OPNET [15] and laboratory test facilities. The simulation models can represent multifunctional relays and power system networks in the same simulation environment so that their interaction during faults can be studied. Communication network within substation automation system can be modeled using the OPNET based tools. A set of lab test facilities provide interfaces to commercial IEDs for students to study the characteristics and evaluate the performance.

The paper starts with description of newly developed modeling and simulation tools for teaching protective relaying and substation communication concepts. Laboratory test

facilities for interfacing multifunctional IEDs are introduced next. Teaching examples for those new approaches are also provided. Conclusions and benefits assessment of developed teaching solutions are given at the end.

## II. SIMULATION AND MODELING TOOLS

The use of modeling and simulation techniques in the smart grid education allows understanding the properties of IEDs, testing integrated solutions as well as evaluating their performance before commission. The simulation tools serve as a common framework for future expansions as the continued needs to incorporate new developments grow.

For representing digital relays and power system models in the same simulation environment so that their interaction during faults can be studied, a set of programs, named MERIT 2000, was developed using MATLAB/SIMULINK [16]. Libraries of protective relay modules, power system elements and protection schemes have been developed for an easy use by students when learning the principles of protective relay design and application. Because of the limited pages, only relay elements library, signal source library and analysis tools, protective relay models and power network elements are presented for describing the comprehensive tools. Other modules such as the various protection scheme models, transformer and busbar protection system and their related power network models are not provided in the paper.

### A. Relay Elements Library

The library of relay elements includes the major modules for designing a protective relay functions such as data acquisition, measurement, decision making and communication. As shown in Figure 1 and Table I, this library allows students to design a variety of relays by selecting, connecting and configuring models of appropriate elements from the library.

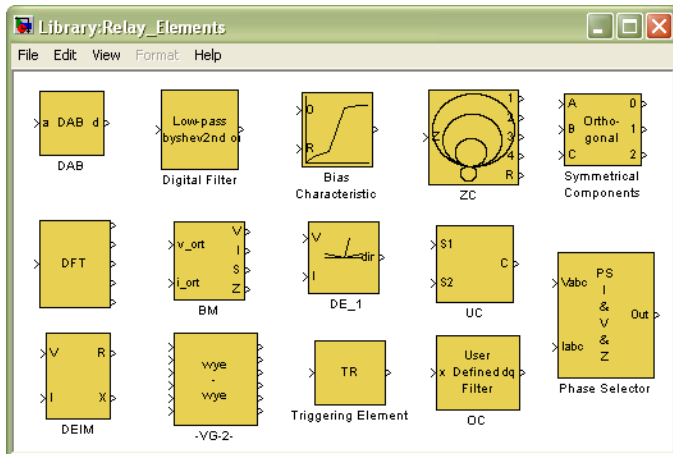

Figure 1. Library of protective relay elements

TABLE I. SUMMARY OF RELAY ELEMENTS LIBRARY

Element	Description
Data Acquisition Board	An analog input signal is filtered for anti-aliasing, conditioned, sampled and forwarded as a data window of signal samples. Options include analog filtering, type, order

(DAB)	and cut-off frequency; number of bits of A/D converter; conditioning gain and length of data window.
Digital Filter (DF)	An input signal is filtered digitally. The predefined filters include various types of IIR filters, and Walsh, Fourier FIR. "Free-expression" digital filter can be set.
Digital Fourier Transform (DFT)	An input data window is captured and the phasors of up to five harmonics are calculated using the DFT technique. The options include selection of the frequency of the reference (first) harmonics and other requested harmonics.
Basic Measurement (BM)	The voltage and current phasors are captured and the amplitudes, impedance components and power are calculated. The post-filtering may be applied using either mean or median filters.
Differential Equation Impedance Measurement (DEIM)	The block measures the impedance based on the differential equation approach. The pre-filtering using either Walsh or Fourier filters of selectable window length may be applied. The post-filtering using either mean or median filters may be applied. Either Euler or trapezoidal method of numerical differentiation may be used.
Universal Comparator (UC)	The block is fed by two signals and does a comparison between the signal or a threshold, the signal and time or the two signals. The direction of comparison may be alternated and the standard time characteristics are included.
Zone Comparator (ZC)	The block is fed by the resistance and reactance values and emulates four forward impedance zones and a reverse one. Either the mho or "free-expression" shapes may be set.
Triggering Element (TR)	The block is fed by the data window of a signal and acts as a transient detector. Implemented methods include sample-to-sample, cycle-to-cycle and value-to-threshold checking.
Symmetrical Components (SC)	The block is fed by three phase signals and produces three symmetrical components signals. Either phasors or instantaneous values are utilized.
Bias Characteristic	The block is fed by the operating and restraining signal and applies a "free-expression" bias characteristic.

### B. Signal Source Library and Analysis Tools

The signal source library generates various input signals for protective relays. As given in Figure 2, it includes transient modeling of power system for closed-loop simulation (link to ATP/EMTP [17] and the SimPowerSystem) as well as the analytical way of generating the signals. In addition, a file format conversion for data from major transient file formats (COMTRADE [18] and MATLAB's native format) is also provided.

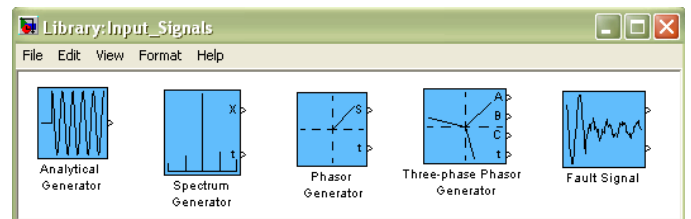

Figure 2. Signal source library

Analysis tools contain functional elements that facilitate the analysis and testing procedures. Take the output phasor display as an example (see Figure 3). This module can be fed by up to six phasors which are multiplexed into a single input vector. It displays them in both the graphical and numerical forms. This block can be disabled. That is presented in the steady state type (the values are displayed when the simulation terminates) or of the transient type (the plot refreshed every given time interval).

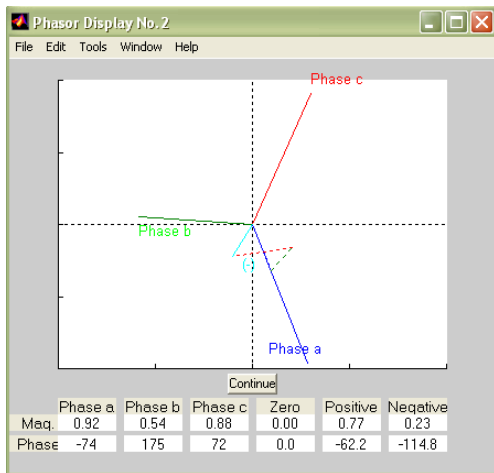

Figure 3. Output phasor display block

### C. Relay Models and Power Network Elements Library

The relay models developed in MERIT2000 contain present models of complete digital relays and protection terminals such as overcurrent, impedance (distance), differential relays. Those models are composed from the blocks of the Relay Elements library and the general SIMULINK libraries. Some of the relay models emulate actual relays to the extent possible using the publicly available design details. Figure 4 presents an example of a three-phase directional overcurrent relay. It features three-phase directional element, three-phase inverse-time and residual overcurrent elements. In this model:

- The DAB and OC module takes analog inputs and simulates the analog filter, signal conditioner, A/D converter and phasor measurement estimator.
- The time overcurrent, residual and directional protection elements take three-phase current, zero-sequence current and phase-to-phase voltages as inputs and perform corresponding functions.
- The logic block analyzes digital inputs and initiates trip signal according to the logic configuration.

From this example one can see that the relay model can be assembled from the available libraries in a very convenient way. Modifications of its structures and parameters are intuitive. Once developed, the model can be packed into a subsystem, seen in Figure 5, and categorized into a library of relays for the future use. This approach can accelerate the model development phase significantly. In the same way, a larger structure of protection system can be built out of relays and relay element libraries.

Once the developed relay model has been verified through testing, it can be applied to the power network protection. Power network library (Figure 6) contains the major elements for constructing an application instance, such as generator, load, transmission line circuit breaker as well as the instrument transformers. Disturbances can be simulated for generating voltages and/or currents fed to relays.

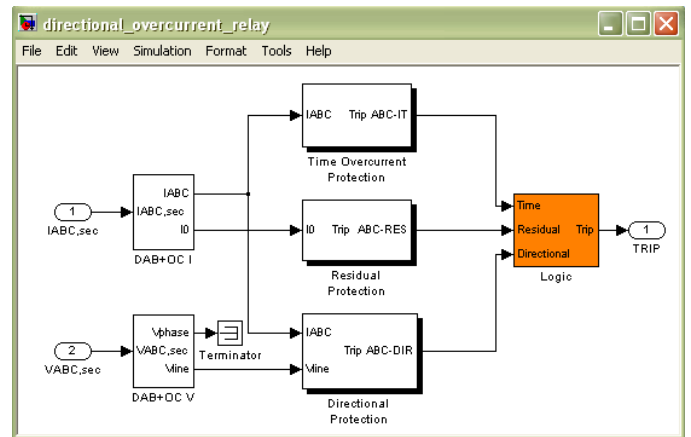

Figure 4. Structure of directional overcurrent relay model

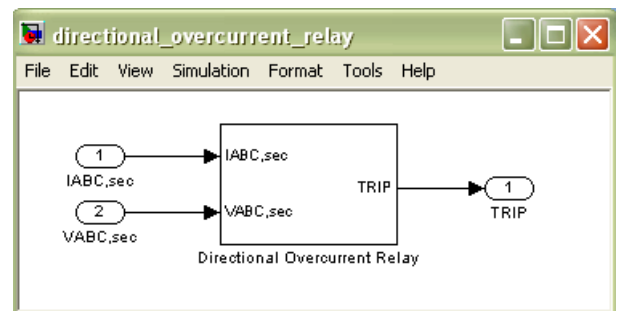

Figure 5. Directional overcurrent relay block

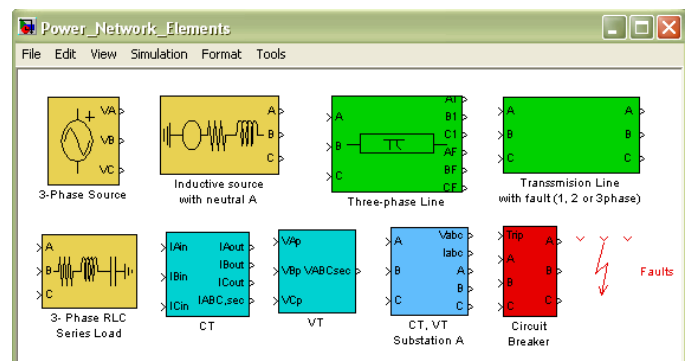

Figure 6. Power network elements library

### D. Simulation Techniques for Substation Communication

As the development of digital information and communication technologies some advanced features, such as synchronized phasor measuring, digital fault recording and network-based communicating, have been embedded into modern relays. This can be effectively used for the purpose of substation automation and data integration. Communication network within Substation Automation System can be modeled using a communication network modeling and simulation tool OPNET with user friendly interface and object-oriented modeling approach. Examples of a protection IED process model and node model are presented as Figure 7 and Figure 8. The simulation techniques are demonstrated to be efficient in teaching fundamentals of the substation communication networks.

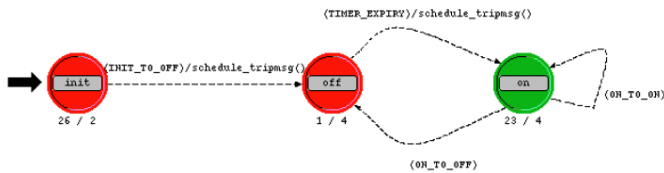

Figure 7. Example of a protection IED process model

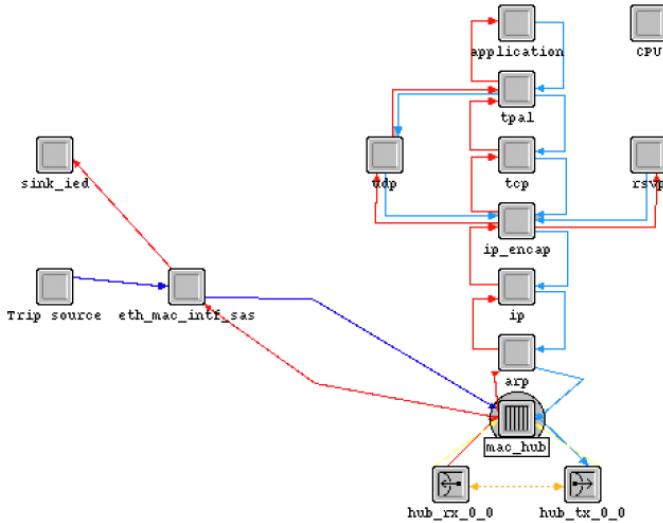

Figure 8. Example of a protection IED node model

### III. LABORATORY TEST FACILITIES

In this section, three sets of laboratory facilities developed to enhance the solution of educational tools are presented: low voltage relay test system, synchrophasor test system, and substation process bus test system. The test facilities enable students to learn in depth performance characteristics of multifunctional IEDs and their compliance with standards by performing tests.

#### A. Relay Test System

A low voltage lab simulatorbased relay test system that provides interface to advanced commercial relays has been developed for students to study the relay characteristics and evaluate the performance of a protection system.

The block diagram given in Figure 9 describes the structure of the relay testing system. It consists of a PC used to run related software, a digital simulator used to generate the low voltage signals, and a signal conditioner used to scale the signals from the digital simulator before feeding them to the physical relay under test. Commercial software Relay Assistant™ resides on the PC and communicates with digital simulator to send transient voltage and current data and receive contact status data. The digital simulator applies the voltage and current waveforms for the relay and records the relay trip contact status. A relay setting software that resides on the PC communicates with the relay to configure relay settings and retrieve relay event reports.

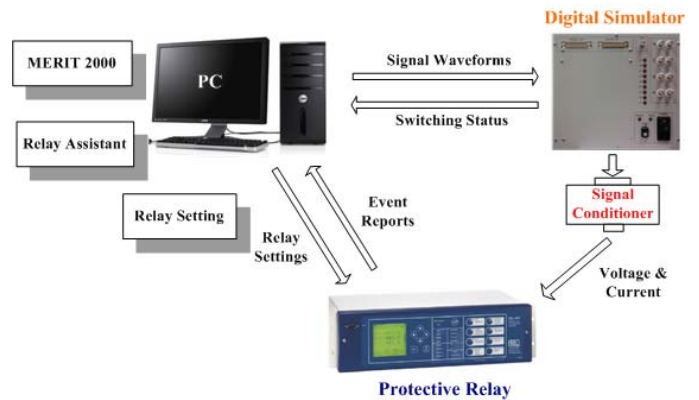

Figure 9. Block diagram of relay test system

Figure 10 shows the laboratory setup. A variety of data formats containing the voltage and current signals can be used as inputs to perform relay tests. That includes the data files generated from the simulations in MERIT 2000 and ATP/EMTP, and the field recorded waveforms, such as the ones captured by DFRs.

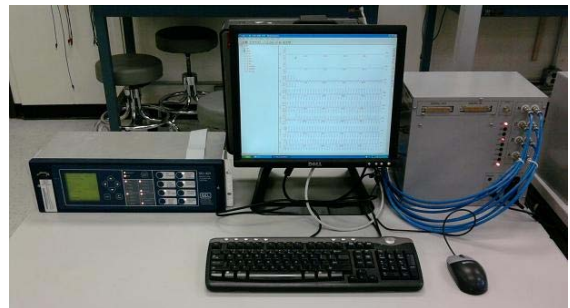

Figure 10. Laboratory setup of relay test system

#### B. Synchrophasor Test System

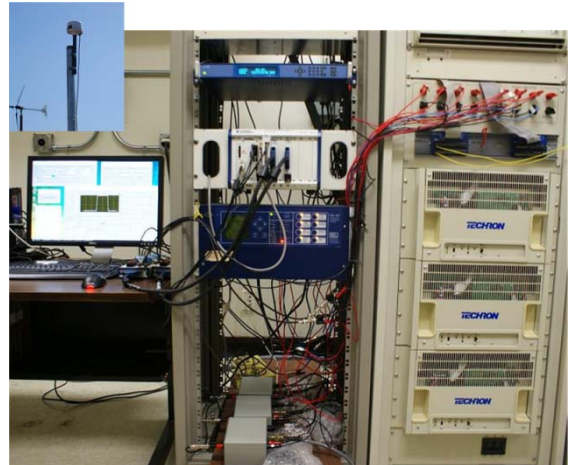

Figure 11. Synchrophasor test system

A synchrophasor test system has been developed for performing calibration and performance tests on GPS-enabled IEDs. As shown in Figure 11 the system consists of a controller (PXIe system by National Instruments), time reference system (global positioning system clock and high

precision receiver), signal source (commercial voltage and current amplifiers) and processing system (instrument transformers). It can be used to verify the design and application performance of synchrophasor function that is integrated in multifunctional relays and other multifunctional IEDs. Data processing interfaces has been developed to adapt to the diversity of signal formats.

### C. Substation Process Bus Test System

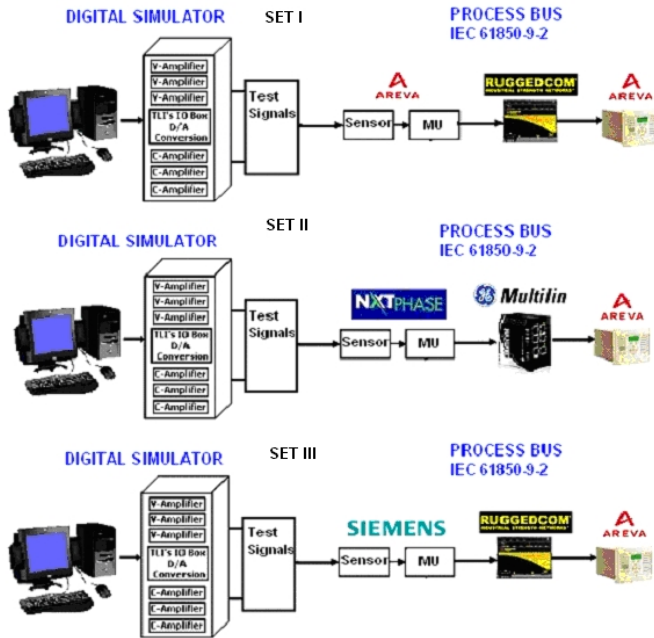

Figure 12. Substation process bus test system

Figure 12 exhibits the structure of substation process bus test system. From the left hand side the system a digital simulator that represents a power system, an interface that scales the analog signals to the input level of the unconventional instrument transformer, merging units, Ethernet switches and digital relays with low level digital inputs. This test system enables testing multiple configurations of the equipment allowing for evaluation of the standard (IEC 61850-9-2) conformance tests and the interoperability tests [19] [20]. This arrangement allows participant in the hands-on experience to evaluate performance of the solution under variety of possible equipment configurations and operating conditions in the power system [21].

## IV. TEACHING EXAMPLES

Teaching examples are presented to show the flexibility and efficiency of the developed simulation tools. The performance characteristics of multifunctional relays and their behavior under various power system disturbances can be studied using such tools. Simulation results in MERIT 2000 using digital relaying models can be analyzed and compared with the results collected from testing actual relays. It is demonstrated how better understanding of relay behavior may lead to improved dependability and security when exposed to various disturbances in power system.

To verify the design and application of either a protective relay model built using developed libraries or a commercial relay, the following signal sources can be used:

- Signal generators of the signal source library.
- Transient signals generated from the disturbance simulation of power system network developed using power network elements library.
- ATP/EMTP output files through simulations.
- Field recorded files in COMTRADE format.

### A. Closed-Loop Impedance Relay Testing

Figure 13 introduces a predefined SIMULINK model for student to practice the implementation of distance relay for protecting an EHV electric power network. The application performance of the protection schemes can be verified in a simple way that places disturbances on transmission lines with various conditions. In this model:

- A three-phase impedance relay model is used to protect a transmission line.
- The 238 kV transmission network is modeled.
- Instrument transformers are used to scale down the voltages and currents for relays.
- Circuit breakers are connected to the trip terminals of corresponding relays.
- Output display elements are used as indicators.

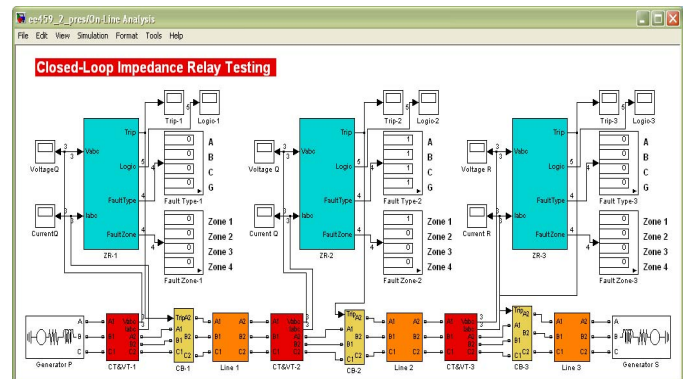

Figure 13. Closed-loop impedance relay testing model

The student assignments for this example consists of

- Configure the impedance relays to implement three-zone (or four-zone) protection scheme.
- Place faults at different locations (with different types, resistances, inception angles) to study the relay operating characteristics and verify the protection scheme.
- Simulate some disturbances occurring in real power system that may fool the relay, such as switching operation, power swing and load encroachment. Observe the relay behaviors and recommend the relay settings.
- Simulate external faults for verifying the back-up protection. Understand idea of the relay coordination and learn the method of coordinating settings.

From this example, the students learn 1) relay design and application issues; 2) relay configurations and settings; 3)

testing methods for verifying the relay design and protection scheme.

### B. Open-Loop Relay Testing

The open-loop model serves as a signal source that generates test scenarios with various conditions for testing either the relay models or actual relays. The relay test system introduced in Section III is used to interface actual relays. Data file format convertors are applied when necessary.

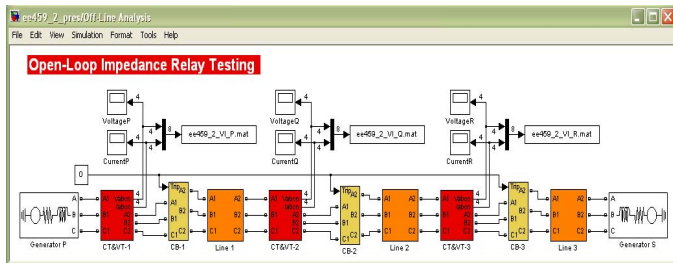

Figure 14. Open-loop relay testing model

The student assignments for this example include

- Simulate different power system events, such as faults, switching operations and power swings. Convert the output data files to correct format and feed them to the relay test system.
- Configure actual relays under test with comprehensive protection logics, such as switch on to fault, power oscillation and load encroachment.
- Observe and analyze relay behaviors under certain conditions. Recommend relay settings.
- Compare test results from relay models and actual relays.

From this example, the student learn 1) basic operations of actual relays; 2) use of relay test system to evaluate relay performances; 3) better understanding the relaying principle through comparison.

### V. CONCLUSION

This paper introduced a set of newly developed modeling, simulation and testing tools. They can be used to study the performance characteristics of multifunctional IEDs and evaluate the integration of substation automation solutions into the smart grid. The main conclusions drawn from the ideas presented in the paper are as follows:

- Multidisciplinary and integrative nature of the smart grid solutions requires new modeling, simulation and testing tools to understand the diverse equipment behavior.
- The hands on experiences with modeling, simulation and testing tools provides needed insights into the integration concepts associated with application of multifunctional IEDs in substation automation solutions
- The simulation techniques and test facilities that provide an ability to study interaction between various devices in a substation facilitate understanding of new communication standards for IEDs.

- Using simulation tools that demonstrate interaction between power system and IEDs allows in-depth studying of the relay dependability and security performance when exposed to the stressed power system conditions.

### VI. REFERENCES

- [1] United States Department of Energy, "Smart Grid." [Online]. Available: <http://www.oe.energy.gov/smartgrid.htm>.
- [2] IEEE PES, "Preparing the U.S. Foundation for Future Electric Energy Systems: A Strong Power and Energy Engineering Workforce," April 2009.
- [3] M. S. Sachdev, M. Nagpal, T. Adu, "Interactive Software for Evaluating and Teaching Digital Relaying Algorithms," *IEEE Trans. Power System*, Vol. 5, pp. 346-352, Feb. 1990.
- [4] P. G. McLaren, C. Henville, V. Skendzic, A. Girgis, M. Sachdev, G. Benmouyal, K. Mustaphi, M. Kezunovic, L. Kojovic, M. Meisinger, C. Simon, T. Sidhu, R. Marttila, D. Tziouvaras, "Software Models for Relays," *IEEE Trans. Power Delivery*, Vol. 16, pp. 238-246, April 2001.
- [5] M. Kezunovic, A. Abur, G. Huang, A. Bose, K. Tomsovic, "The Role of Digital Modeling and Simulation in Power Engineering Education," *IEEE Trans. Power System*, Vol. 19, pp. 64-72, Feb. 2004.
- [6] Y. Tamura, E. Dan, I. Horie, Y. Nakkanishi, S. Yokokawa, "Development of Power System Simulator for Research and Education," *IEEE Trans. Power System*, Vol. 5, pp.492-298, May 1990.
- [7] C. Y. Teo, H. B. Gooi, "A Microcomputer Based Integrated Generation and Transmission System Simulator," *IEEE Trans. Power System*, Vol. 10, pp. 44-50, Feb. 1995.
- [8] E. K. Tam, F. Badra, R. J. Marceau, M. A. Marin, A. S. Malowany, "A Web-based Virtual Environment for Operator Training," *IEEE Trans. Power System*, Vol. 14, pp. 802-808, Aug. 1999.
- [9] J. A. Huang, F. D. Galiana, "An Integrated Personal Computer Graphics Environment for Power System Education, Analysis and Design," *IEEE Trans. Power System*, Vol. 6, pp. 1279-1285, Aug. 1991.
- [10] A. M. Gole, O. B. Nayak, T. S. Sidhu, M. S. Sachdev, "A Graphical Electromagnetic Simulation Laboratory for Power Systems Engineering Programs," *IEEE Trans. Power System*, Vol. 11, pp. 599-606, May 1996.
- [11] J. Yang, M. D. Anderson, "PowerGraf: An Educational Software Package for Power Systems Analysis and Design," *IEEE Trans. Power System*, Vol. 13, pp. 1205-1210, Nov. 1998.
- [12] M. Kezunović, "A Survey of Engineering Tools for Protective Relaying," *ELECTRA*, No. 225, pp 26-30, April 2006.
- [13] The MathWorks Inc., Using MATLAB, Natick, Massachusetts, Jan. 1999. [Online]. Available: <http://www.mathworks.com/>
- [14] Using SIMULINK, The Mathworks Inc., Nov. 2000.
- [15] OPNET Modeler, OPNET Technologies. [Online]. Available: <http://www.opnet.com>.
- [16] M. Kezunovic, "User Friendly, Open System Software for Teaching Protective Relaying Application and Design Concepts," *IEEE Trans. Power System*, Vol. 18, No. 3, pp. 986-992, August 2003.
- [17] CanAm EMTP User Group, Alternative Transient Program (ATP) Rule Book, Portland, OR, 2001. [Online]. Available: [http://www.eeug.org/files/secret/ATP\\_RuleBook](http://www.eeug.org/files/secret/ATP_RuleBook)
- [18] IEEE Standard Common Format for Transient Data Exchange (COMTRADE), IEEE Standard C37.111-1999, March 1999.
- [19] Communication networks and systems in substation-Part 9-2: Specific communication service mapping (SCSM)- Sampled analogue values over ISO 8802-3, IEC Std. 61850.
- [20] Communication networks and systems in substation-Part 10: Conformance testing, IEC Std. 61850.
- [21] P. Zhang, L. Portillo, M. Kezunovic, "Compatibility and Interoperability Evaluation for All-Digital protection System through Automatic Application Test," *IEEE PES General Meeting*, Montreal, 2006.